



- (b) A 20m chain was found to be 8cm too long at the end of days work after measuring 4000m. If the chain was correct before the commencement of work, find the correct length of the line. (6)

**Q-3 Attempt all questions**

- (a) The following are the fore bearing and back bearing of the lines of a closed traverse. Calculate the interior angles of the traverse. (10)

Line	AB	BC	CD	DE	EA
Fore Bearing	150°15'	20°30'	295°45'	218°	120°30'
Back Bearing	330°15'	200°30'	115°45'	38°	300°30'

- (b) Enumerate different types of conventional symbols used in surveying with a neat sketch. (4)

**Q-4 Attempt all questions**

- (a) Enumerate the various methods of seasoning of timber in detail. (6)
- (b) Write short note on aluminium with its uses and properties. (4)
- (c) What are the types of concrete? Explain the properties of concrete. (4)

**Q-5 Attempt all questions**

- (a) What are the key components of GIS and draw its essentials of GIS. (6)
- (b) What are the three segments of GPS? Write the uses of GPS. (4)
- (c) Enumerate the various ceramic products. Write importance of ceramics as a building construction material. (4)

**Q-6 Attempt all questions**

- (a) A mechanism shown in figure.1 is hinged at A, is acted by horizontal force of 500N at C. Determine least force 'P' required at E for equilibrium of the mechanism and corresponding angle 'θ'. (8)
- (b) Determine magnitude and direction of resultant force of the force system shown in below figure.2. (6)



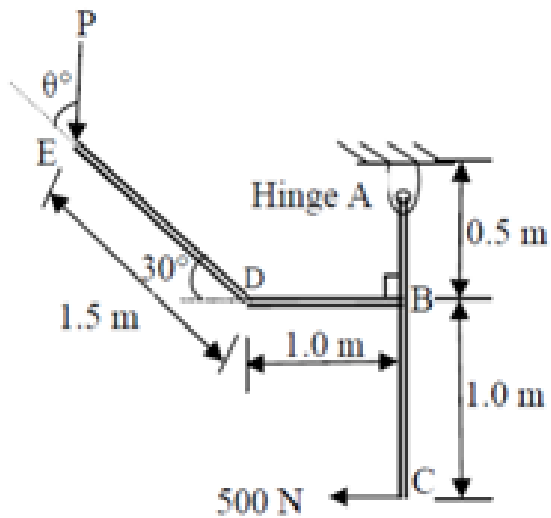

Figure.1.

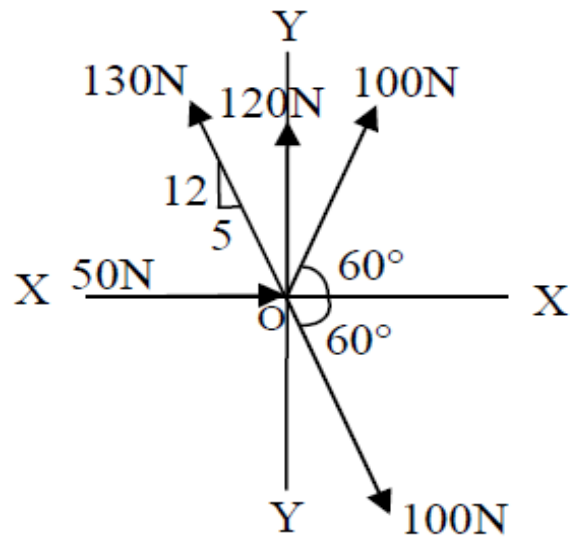
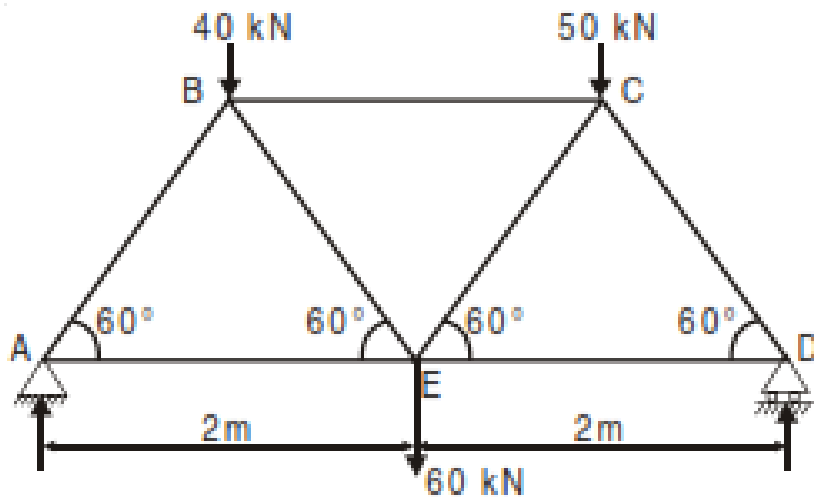

Figure.2.

Q-7

Attempt all questions

- (a) Determine the forces in all the members of the truss shown in Figure. All inclined members are at  $60^\circ$  to horizontal and length of each member is 2 m. (8)



- (b) Explain with sketches perfect truss and imperfect truss. (4)
- (c) What are the uses of truss? (2)

Q-8

Attempt all questions

- (a) Find centroid of a section shown in the figure. (6)



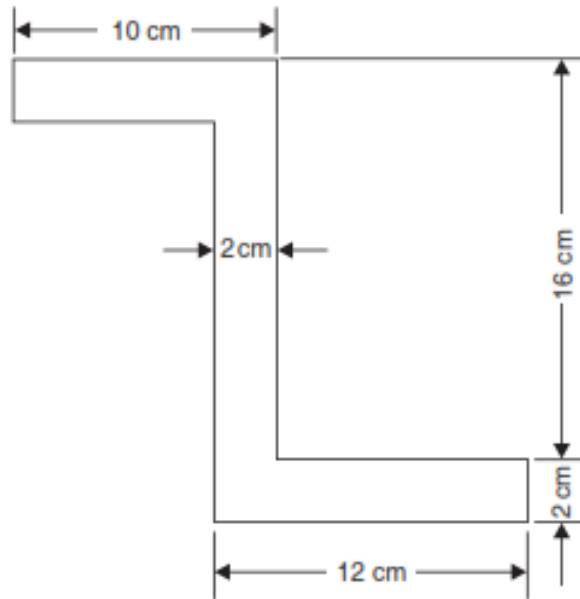

(b) Determine the  $I_{yy}$  of section shown in Figure.

(8)

